

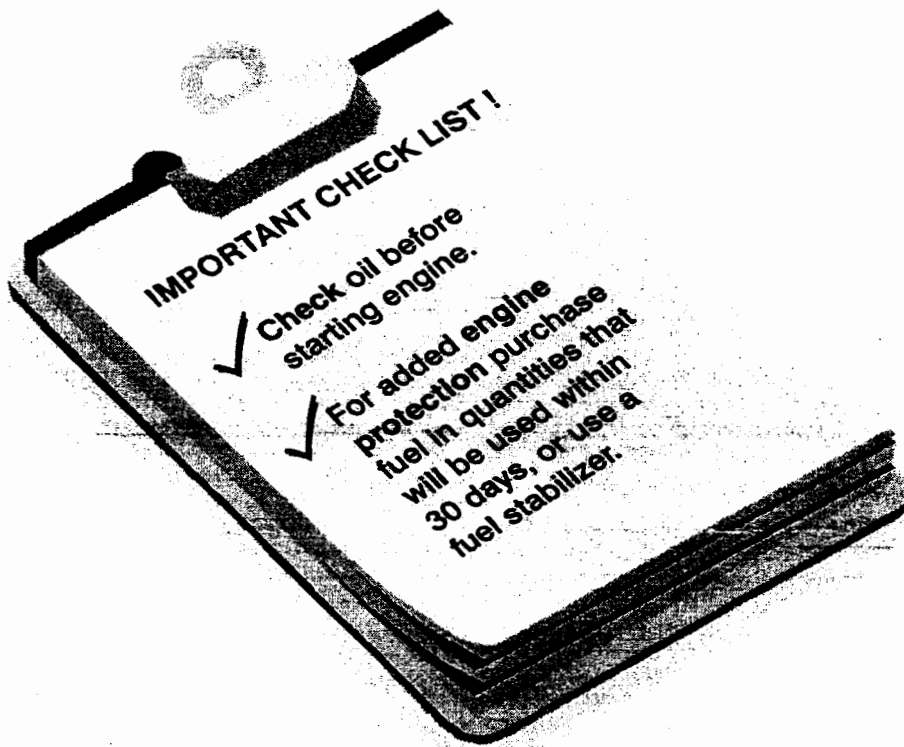

Owner's Manual

◆ SET-UP ◆ OPERATION ◆ MAINTENANCE



IMPORTANT: Read Safety Rules and Instructions Carefully

PRINTED IN CANADA

OGST-2705

CALLING CUSTOMER SUPPORT

- **LOCATE YOUR MODEL NUMBER AND SERIAL NUMBER** which appears on your unit and record the information in the space provided below.

IMPORTANT: You must have these numbers, along with the date and proof of purchase to receive warranty or service.

- If you are having difficulty assembling this product or if you have any questions regarding the controls, operation or maintenance of this unit, please call an authorized dealer.
- Please have your model number and serial number ready when you call.

NOTE: Although both numbers are important, you will be asked to enter only your serial number before your call can be processed.

Model Number Numéro de modèle	Serial Number Numéro de série
XXXXXXXXXX	XXXXXXXXXX
COLUMBIA COLUMBIA CANADA KITCHENER, ON N2G 4J1	

This is where your model number will be, record Model Number here:

This is where your serial number will be, record Serial Number here:

This unit has been inspected against the manufacturers quality check list. In case of a discrepancy, please call us. We will make every effort to ship the part(s) by courier within one working day of your call.

IMPORTANT SAFE OPERATION PRACTICES



WARNING: This symbol points out important safety instructions which, if not followed, could endanger the personal safety and/or property of yourself and others. Read and follow all instructions in this manual before attempting to operate this machine. Failure to comply with these instructions may result in personal injury. When you see this symbol —heed its warning.



DANGER: This machine was built to be operated according to the rules for safe operation in this manual. As with any type of power equipment, carelessness or error on the part of the operator can result in serious injury. This machine is capable of amputating hands and feet and throwing objects. Failure to observe the following safety instructions could result in serious injury or death.

TRAINING

1. Read, understand, and follow all instructions on the machine and in the manual(s) before attempting to assemble and operate. Keep this manual in a safe place for future and regular reference and for ordering replacement parts.
2. Be familiar with all controls and their proper operation. Know how to stop the machine and disengage them quickly.
3. Never allow children under 14 years old to operate this machine. Children 14 years old and over should read and understand the operation instructions and safety rules in this manual and should be trained and supervised by a parent.
4. Never allow adults to operate this machine without proper instruction.
5. Thrown objects can cause serious personal injury. Plan your snow throwing pattern to avoid discharge of material toward roads, bystanders and the like.

6. Keep bystanders, helpers, pets and children at least 75 feet from the machine while it is in operation. Stop machine if anyone enters the area.
7. Exercise caution to avoid slipping or falling, especially when operating in reverse.

PREPARATION

1. Thoroughly inspect the area where the equipment is to be used. Remove all door mats, newspapers, sleds, boards, wires and other foreign objects which could be tripped over or thrown by the auger/impeller.
2. Always wear safety glasses or eye shields during operation and while performing an adjustment or repair to protect your eyes. Thrown objects which ricochet can cause serious injury to the eyes.
3. Do not operate without wearing adequate winter outer garments. Do not wear jewelry, long scarves or other loose clothing which could become entangled in moving parts. Wear footwear which will improve footing on slippery surfaces.
4. Use a grounded three wire extension cord and receptacle for all units with electric start engines.
5. Adjust collector housing height to clear gravel or crushed rock surfaces.
6. Disengage all clutch levers before starting the engine.
7. Never attempt to make any adjustments while engine is running, except where specifically recommended in the operator's manual.
8. Let engine and machine adjust to outdoor temperature before starting to clear snow.
9. To avoid personal injury or property damage use extreme care in handling gasoline. Gasoline is extremely flammable and the vapors are explosive. Serious personal injury can occur when gasoline is spilled on yourself or your clothes which can ignite. Wash your skin and change clothes immediately.
 - a. Use only an approved gasoline container.
 - b. Extinguish all cigarettes, cigars, pipes and other sources of ignition.

- c. Never fuel machine indoors.
- d. Never remove gas cap or add fuel while the engine is hot or running.
- e. Allow engine to cool at least two minutes before refueling.
- f. Never over fill fuel tank. Fill tank to no more than ½ inch below bottom of filler neck to provide space for fuel expansion.
- g. Replace gasoline cap and tighten securely.
- h. If gasoline is spilled, wipe it off the engine and equipment. Move machine to another area. Wait 5 minutes before starting the engine.
- i. Never store the machine or fuel container inside where there is an open flame, spark or pilot light (e.g. furnace, water heater, space heater, clothes dryer etc.).
- j. Allow machine to cool at least 5 minutes before storing.

OPERATION

1. Do not put hands or feet near rotating parts, in the auger/ impeller housing or discharge chute. Contact with the rotating parts can amputate hands and feet.
2. The auger/impeller clutch lever is a safety device. Never bypass its operation. Doing so, makes the machine unsafe and may cause personal injury.
3. The clutch levers must operate easily in both directions and automatically return to the disengaged position when released.
4. Never operate with a missing or damaged discharge chute. Keep all safety devices in place and working.
5. Never run an engine indoors or in a poorly ventilated area. Engine exhaust contains carbon monoxide, an odorless and deadly gas.
6. Do not operate machine while under the influence of alcohol or drugs.
7. Muffler and engine become hot and can cause a burn. Do not touch.
8. Exercise extreme caution when operating on or crossing gravel surfaces. Stay alert for hidden hazards or traffic.
9. Exercise caution when changing direction and while operating on slopes.

10. Plan your snow throwing pattern to avoid discharge towards windows, walls, cars etc. To avoid property damage or personal injury caused by a ricochet.
11. Never direct discharge at children, bystanders and pets or allow anyone in front of the machine.
12. Do not overload machine capacity by attempting to clear snow at too fast of a rate.
13. Never operate this machine without good visibility or light. Always be sure of your footing and keep a firm hold on the handles. Walk, never run.
14. Disengage power to the auger/impeller when transporting or not in use.
15. Never operate machine at high transport speeds on slippery surfaces. Look down and behind and use care when in reverse.
16. If the machine should start to vibrate abnormally, stop the engine, disconnect the spark plug and ground it against the engine. Inspect thoroughly for damage. Repair any damage before starting and operating.
17. Disengage all clutch levers and stop engine before you leave the operating position (behind the handles). Wait until the auger/impeller comes to a complete stop before unclogging the discharge chute, making any adjustments, or inspections.
18. Never put your hand in the discharge or collector openings. Always use the clean-out tool provided to unclog the discharge opening. Do not unclog discharge chute while engine is running.
19. Use only attachments and accessories approved by the manufacturer (e.g. wheel weights, tire chains, cabs etc.).
20. If situations occur which are not covered in this manual, use care and good judgment. Contact the customer support department.

MAINTENANCE AND STORAGE

1. Never tamper with safety devices. Check their proper operation regularly. Refer to the maintenance and adjustment sections of this manual.
2. Before cleaning, repairing, or inspecting machine disengage all clutch levers and stop engine. Wait until the auger/impeller come to a complete stop. Disconnect the spark plug wire and ground against the engine to prevent unintended starting.
3. Check bolts, and screws for proper tightness at frequent intervals to keep the machine in safe working condition. Also, visually inspect machine for any damage.
4. Do not change the engine governor setting or over-speed the engine. The governor controls the maximum safe operating speed of the engine.
5. Snowthrower shave plates and slide shoes are subject to wear and damage. For your safety protection, frequently check all components and replace with original equipment manufacturer's (OEM) parts only. "Use of parts which do not meet the original equipment specifications may lead to improper performance and compromise safety!"
6. Check clutch controls periodically to verify they engage and disengage properly and adjust, if necessary. Refer to the adjustment section in this operator's manual for instructions.
7. Maintain or replace safety and instruction labels, as necessary.
8. Observe proper disposal laws and regulations for gas, oil, etc. to protect the environment.
9. Prior to storing, run machine a few minutes to clear snow from machine and prevent freeze up of auger/impeller.
10. Never store the machine or fuel container inside where there is an open flame, spark or pilot light such as a water heater, furnace, clothes dryer etc.
11. Always refer to the operator's manual for proper instructions on off-season storage.

		<p>WARNING - Your Responsibility: Restrict the use of this power machine to persons who read, understand and follow the warnings and instructions in this manual and on the machine.</p>
---	---	---

ASSEMBLY INSTRUCTIONS

NOTE: The snowthrower is shipped with oil and **WITHOUT GASOLINE**. After assembly, refer to separate engine manual for proper fuel and engine oil recommendations.

AUGER SHEAR BOLTS

The augers are secured to the spiral shaft with two shear bolts and hex flange locknuts. Two replacement hex bolts and hex flange locknuts have been provided for your convenience. Store in a safe place until needed.

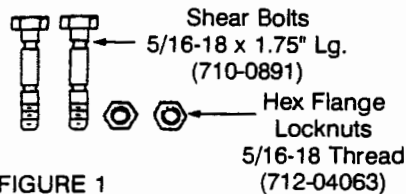

FIGURE 1

NOTE: Reference to right hand or left hand side of machine are observed from the operating position.

IMPORTANT: Check the adjustments as instructed on page 10, and make any final adjustments necessary before operating your snow thrower. Failure to follow the instructions may cause damage to the snow thrower.

- Remove staples or break glue on the top flaps of the carton. Remove any loose parts included with unit (i.e., owner's manual, etc.).
- Cut along dotted lines and lay end of carton down flat. Remove packing material.
- Roll unit out of carton. Check carton thoroughly for loose parts or literature.
- Remove the **lower** two plastic wing nuts, cupped washers and carriage bolts from each side of the lower handle. See Figure 2.
- Raise the upper handle assembly until it locks over the lower handle. See Figure 2 and 3.

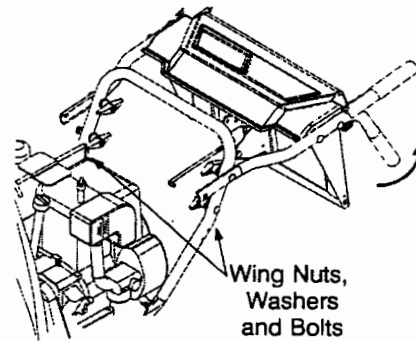

FIGURE 2

- Secure the upper handle and lower handle with the two plastic wing nuts, cupped washers and carriage bolts previously removed. See Figure 3.
- Slide the shift rod connector down over the end of the lower shift rod. See Figure 4. Tap the connector until it locks on the lower shift rod.

NOTE: If the connector is not properly assembled, the shift rod will pivot and you will not be able to shift gears or change directions.

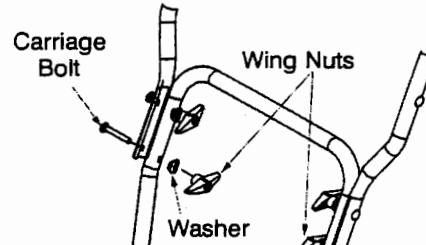

FIGURE 3

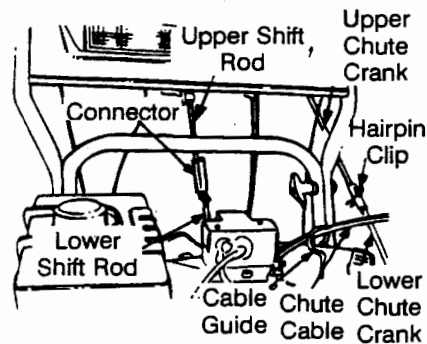

FIGURE 4

- Remove the hairpin clip from the end of the upper chute crank. Slide the upper chute crank into the lower chute crank. Align the holes, and secure with hairpin clip. See Figure 4.
- The cable ties normally are loosely installed on each side of the lower handle at the factory. Pull the cable ties tight to secure. Trim excess from the ends of cable ties.
- If not already attached, slip the cables that run from the handle panel to the chute into the cable guide located on top of the engine. See Figure 4.

FINAL ASSEMBLY AND ADJUSTMENTS

Slide Shoe Adjustment

The space between the shave plate and the ground can be adjusted. For close snow removal, place slide shoes in the low position. Use middle or high position when area to be cleared is uneven. See Figure 5.

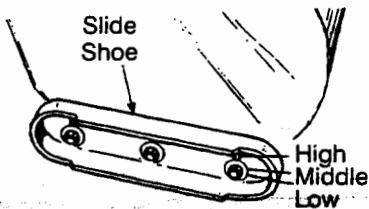

FIGURE 5

- Adjust slide shoes by loosening the hex nuts, washers and carriage bolts and moving slide shoes to desired position. Make certain the entire bottom surface of slide shoe is against the ground to avoid uneven wear on the slide shoes. Tighten bolts securely.

CHUTE CLEAN-OUT TOOL

The chute clean-out tool is conveniently fastened to the rear of the auger housing with a mounting clip. Use the clean-out tool to clear snow and ice which may lodge in the discharge chute during operation. Refer to the Operation section for more detailed information regarding the chute clean-out tool.

LAMP WIRING CONNECTION (optional)

- Wrap the wire from the lamp down the right handle until the wire can be plugged into the alternator lead wire under the fuel tank.

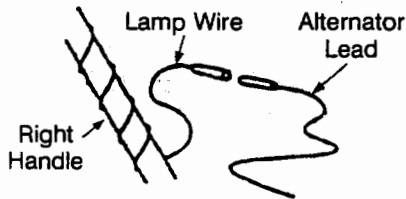

BEFORE STARTING

NOTE: The crankcase has been filled with oil and factory tested. Paint on the muffler may have burnt due to testing.

ATTENTION: YOU MUST CHECK OIL LEVEL BEFORE OPERATION. LEVEL MUST BE AT FULL MARK ON DIPSTICK BEFORE ENGINE IS STARTED.

Failure to follow this procedure may result in serious engine damage which will not be covered by warranty.

Your unit may be equipped with a plastic fuel plug at the opening of the fuel tank. Please remove and discard the plug before filling your unit with gas or before putting the unit into operation.

GAS AND OIL FILL-UP

Service the engine with gasoline and oil as instructed in the separate engine manual packed with your snowthrower. Read instructions carefully.

WARNING: Never fill fuel tank indoors. Never fill fuel tank with engine running or while engine is hot. Do not smoke when filling fuel tank.

OPERATION

TO START ENGINE

- Make certain the metal loop on the end of the spark plug wire (inside the boot) is fastened securely over the metal tip on the spark plug. See Figure 6.

- Make certain the auger and drive clutch levers are in the disengaged (released) position.
- Move throttle control up to FAST position. Insert ignition key into slot. See Figure 7. Be certain it snaps into place. Do not turn key.

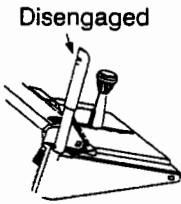

Electric Starter (Optional)

WARNING: The optional electric starter is equipped with a three-wire power cord and plug, and is designed to operate on 120 volt AC Household current. It must be properly grounded at all times to avoid the possibility of electric shock which may be injurious to the operator.

Follow all instructions carefully. Determine that your house wiring is a three wire grounded system. Ask a licensed electrician if you are not certain. If your house wiring system is not a three-wire grounded system, do not use this electric starter under any conditions. If your system is grounded and a three hole receptacle is not available at the point your starter will normally be used, one should be installed by a licensed electrician.

When connecting the power cord, always connect cord to starter on engine first, then plug the other end into a three-hole grounded receptacle.

When disconnecting the power cord, always unplug the end from the three-hole grounded receptacle first.

- Rotate choke knob to FULL choke position.
- Push primer button two or three times as instructed in the separate engine manual. See Figure 7.

NOTE: Always cover vent hole in primer button when pushing. Additional priming may be necessary for first start if temperature is below 15°F (-9°C).

- Connect power cord to switch box on engine. Plug the other end of power cord into a three-hole, grounded 120 volt AC receptacle.



FIGURE 6

ENGINE WILL NOT START UNLESS IGNITION KEY IS INSERTED INTO IGNITION SLOT IN CARBURETOR COVER. DO NOT TURN IGNITION KEY.

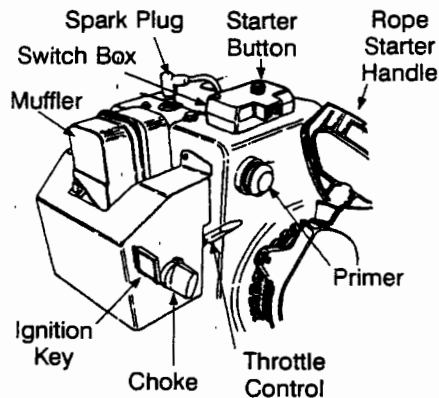

FIGURE 7 - Your engine may be slightly different from the engine shown .



- Push starter button to crank engine. See Figure 7.
- When engine starts, release starter button, and move choke gradually to OFF. If engine falters, move choke immediately to FULL and then gradually to OFF.

Recoil Starter:

- Rotate choke knob to FULL choke position (cold engine start). If engine is warm, place choke in OFF position instead of FULL.
- Push primer button two or three times as instructed in the separate engine manual. See Figure 7. If engine is warm, push primer button once only.

NOTE: Always cover vent hole in primer button when pushing. Additional priming may be necessary for first start if temperature is below 15°F.

- Grasp starter handle (see Figure 7) and pull rope out slowly, until it pulls slightly harder. Let rope rewind slowly.
- Pull starter handle rapidly. Do not allow handle to snap back. Allow it to rewind slowly while keeping a firm hold on the starter handle. Repeat until engine starts.
- As engine warms up and begins to operate evenly, rotate choke knob slowly to OFF position. If engine falters, return to FULL choke, then slowly move to OFF position.

TO STOP ENGINE

- Run engine for a few minutes before stopping to help dry off any moisture on the engine.
- To help prevent possible freeze-up of starter, proceed as follows:

Optional Electric Starter: Connect power cord to switch box on engine, then to 120 volt AC receptacle. With the engine running, push starter button and spin the starter for several seconds. The unusual sound made by spinning the starter will not harm engine or starter. Disconnect the power cord from receptacle first, and then from switch box.

Recoil Starter: With engine running, pull starter rope with a rapid, continuous full arm stroke three or four times. Pulling the starter rope will produce a loud clattering sound, which is not harmful to the engine or starter.

- To stop engine, remove the ignition key. Do not turn key. Disconnect the spark plug wire from the spark plug to prevent accidental starting while equipment is unattended.

NOTE: Do not lose ignition key. Keep it in a safe place. Engine will not start without the ignition key.

- Wipe all snow and moisture from the carburetor cover in the area of the control levers. Also, move control levers back and forth several times.

CONTROLS

Control positions and information markings, on your machine are in international symbols, as explained.



Calls your attention to instructions concerning personal safety.



AUGER CLUTCH GRIP

Located on left hand handle. Squeeze to engage. Release to stop.



DRIVE CLUTCH GRIP

Located on right hand handle. Squeeze to engage. Release to stop.



Keep bystanders, helpers, pets and children at least 75 feet from the machine while it is in operation.



Avoid injury from rotating auger - keep hands, feet and clothing away.



Never put hand in chute. Contact with rotating parts can amputate fingers and hands. Use clean-out tool to unclog discharge chute.

TO ENGAGE DRIVE

- With the engine running near top speed, move shift lever into one of the possible FORWARD or REVERSE positions. Select a speed appropriate for the snow conditions that exist. Use the slower speeds until you are familiar with the operation of the snowthrower.
- Squeeze the left hand auger clutch grip and engage it.
- While the left hand auger clutch grip is engaged, engage the right hand drive clutch grip.

- Release the left hand auger clutch grip only. The interlock mechanism should keep the left hand clutch engaged until the right hand clutch is released.

NOTE: Never move shift lever without first releasing the drive clutch.

CHUTE CLEAN-OUT TOOL

- ⚠ **WARNING:** Stop the engine by removing the ignition key and wait for ALL moving parts to stop, before using the clean-out tool.

The chute clean-out tool is conveniently fastened to the rear of the auger housing with a mounting clip. Should snow and ice lodge itself in the discharge chute during operation, proceed as follows to safely clean the chute and chute opening:

- Release both auger and drive clutch grips.
- Stop the engine by removing the ignition key.
- Remove the clean-out tool from the clip which secures it to the rear of the auger housing.
- Use the shovel-shaped end of the clean-out tool to dislodge and scoop any snow and ice which has formed in and near the discharge chute.

- ⚠ **WARNING:** Never use your hands to clean snow and ice from the discharge chute or auger housing.

- Refasten the clean-out tool to the mounting clip on the rear of the auger housing, reinsert the ignition key and start the snow thrower's engine.
- While standing in the operator's position (behind the snow thrower), engage the auger clutch lever for a few seconds to clear any remaining snow and ice from the discharge chute.

TRIGGER LEVERS (optional)

The trigger levers are located on the underside of the handles and used to steer your snowthrower. See Figure 8. To turn right, squeeze the right trigger lever and guide the snowthrower to the

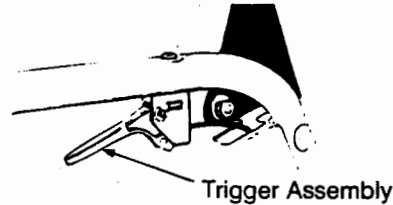

FIGURE 8

right. Squeeze and guide the left lever to turn left. These controls should be used while operating your snowthrower in open areas until you become familiar with their operation.

Squeeze both triggers to free wheel or to transport unit.

TIRE PRESSURE

Pneumatic tires only. Tires are over-inflated for shipping purposes. Correct tire pressure is 10-15 psi.

OPERATING TIPS

NOTE: Allow the engine to warm up for a few minutes as the engine will not develop full power until it reaches operating temperature.

- ⚠ **WARNING:** Temperature of muffler and surrounding areas may exceed 150°F. Avoid these areas.

- For most efficient snow removal, remove snow immediately after it falls.
- Discharge snow downwind whenever possible. The distance snow is thrown can be adjusted by adjusting the angle of the chute assembly. The sharper the angle, the shorter the distance snow is thrown. Slightly overlap each previous swath.
- Set the slide shoes 1/4" below the scraper bar for normal usage. The slide shoes may be adjusted upward for hard-packed snow. Adjust downward when using on gravel or crushed rock.
- Be certain to follow the precautions listed under previous section, "To Stop Engine" to prevent possible freeze up.
- Clean the snowthrower thoroughly after each use.

ADJUSTMENTS

⚠ WARNING: NEVER attempt to clean chute or make any adjustments while engine is running.

REMOTE CHUTE ASSEMBLY ADJUSTMENT

The remote chute control cables have been pre-adjusted at the factory. Move the remote chute lever on the control panel back and forward to adjust angle of the chute assembly.

CARBURETOR ADJUSTMENT

Minor carburetor adjustment may be required to compensate for differences in fuel, temperature, altitude and load.

Refer to the separate engine manual packed with your unit for carburetor adjustment information.

NOTE: Failure to comply with suggested maintenance and lubrication specifications will void warranty.

CHECK ADJUSTMENT OF CLUTCH CABLES

Proper adjustment is achieved by sliding the spring up the cable and threading the nut in or out. Correct adjustment on cables is minimal slack but not tight.

AUGER BELT ADJUSTMENT

Periodic adjustment of the belt tension may be required due to normal stretch and wear on the belt. Increase belt tension if the augers hesitate while the augers are engaged or decrease tension if the the augers continue to turn when the augers are disengaged. To adjust, disconnect ferrule from the brake bracket assembly (Figure 16) and thread ferrule in (towards idler) to increase tension on belt, out to decrease tension.

SHIFT ROD ADJUSTMENT

- To adjust the shift rod, remove the cotter pin which secures the ferrule to the shift lever.
- Place the shift lever in the fastest forward position. Push the shift rod down

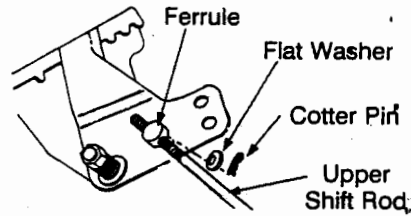

FIGURE 9

sharply, as far as it will go, to put the drive into the fastest forward position. Thread the ferrule in or out on the shift rod as necessary until the ferrule lines up with the upper hole in the shift lever. Insert ferrule from the right side of the snowthrower into upper hole in shift lever and secure with flat washer and internal cotter pin. See Figure 9.

SLIDE SHOE ADJUSTMENT

The space between the shave plate and the ground can be adjusted. Refer to "Final Assembly and Adjustment".

LUBRICATION

WHEELS

Oil or spray lubricant into bearings at wheels at least once a season. Remove wheels, clean and coat axles with a multi-purpose automotive grease.

CHAINS AND SHIFTING MECHANISM

Remove rear cover. Oil all chains, sprockets, bearings, the hexagonal shaft, round shaft and shifting mechanism at least once a season. Use engine oil or a spray lubricant. Avoid getting oil on rubber friction wheel and aluminum drive plate.

CHUTE CRANK WORM

The worm gear on the chute direction crank should be greased with multi-purpose automotive grease.

AUGER SHAFT

Remove auger bolts on auger shaft, see See Figure 11. Oil or spray lubricant inside shaft.

ENGINE

Refer to engine manual for engine lubrication instructions.

! WARNING: When following instructions in separate engine manual for draining oil, be sure to protect frame to avoid oil dripping onto transmission parts.

HEX SHAFT

Lubricate the gear (hex) shaft with a light weight cold weather lubricant at least once a season or after every 25 hours of operation.

IMPORTANT: Keep all grease and oil off of the rubber friction wheel and aluminum drive plate.

If for any reason your transmission was disassembled and the auger cable disconnected, reassemble routing the cable so it does not interfere with any moving parts when pulled tight.

MAINTENANCE

! WARNING: Disconnect the spark plug wire and ground against the engine before performing any repairs or maintenance

AUGERS

The augers are secured to the spiral shaft with two shear bolts and hex locknuts. See Figure 11. If you hit a foreign object or ice jam, the snowthrower is designed so that the shear bolts will shear.

If the augers will not turn, check to see if the hex bolts have sheared. Two replacement hex bolts and hex lock nuts have been provided with the snowthrower. When replacing bolts, spray an oil lubricant into shaft before inserting new bolts.

SHAVE PLATE AND SLIDE SHOES

The shave plate and slide shoes on the bottom of the snowthrower are subject to wear. They should be checked periodically and replaced when necessary.

MAINTENANCE and LUBRICATION CHECK LIST

	After First 2 Hours	After 5 Hours	Frequently	Beginning Each Season	Before Storage
Check engine oil level		•		•	
Change engine oil	•			•	
Tighten all screws and nuts			•		
Check spark plug				•	
Lubricate chute opening				•	
Lubricate wheel axle				•	
Lubricate wheel bearings				•	
Lubricate chains, bearings, and hex shaft				•	•
Check wear on friction wheel rubber				•	
Check auger pulley(s) and auger drive belts			•		

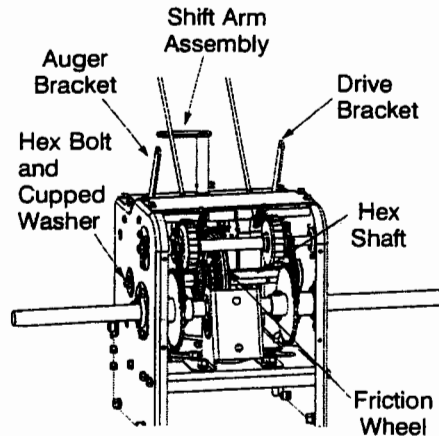

FIGURE 10

NOTE: Some models are equipped with reversible slide shoes.

To remove slide shoes, remove the carriage bolts, cupped washers and hex nuts which attach them to the snowthrower. Reassemble new slide shoes with the carriage bolts, cupped washers (cupped side goes against slide shoes) and hex nuts.

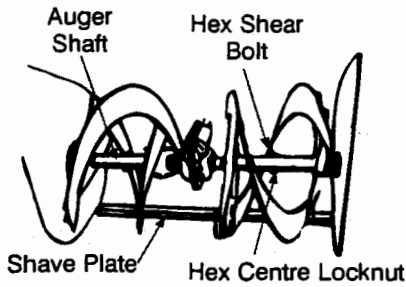

FIGURE 11

To remove shave plate, remove slide shoes as previously instructed, remove the carriage bolts, cupped washers and hex nuts which attach it to the snowthrower housing. Reassemble new shave plate, making sure heads of the carriage bolts are to the inside of the housing. Tighten securely.

BELT REMOVAL AND REPLACEMENT

⚠ WARNING: Remove the spark plug wire from the spark plug and ground. Drain gasoline from the fuel tank, or place a piece of plastic film underneath the gas cap to prevent gasoline from leaking.

Auger Drive Belt

To remove and replace either the auger drive belt or the drive belt, proceed with the following instructions.

- Disconnect chute crank assembly at the discharge chute by removing the cotter pin and flat washer. See Figure 12.

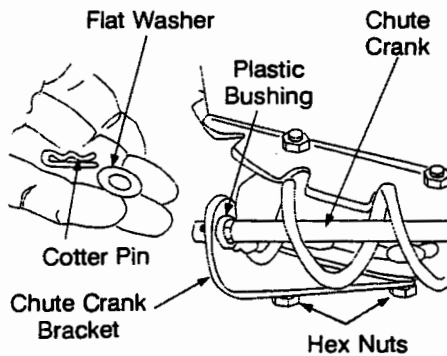

FIGURE 12

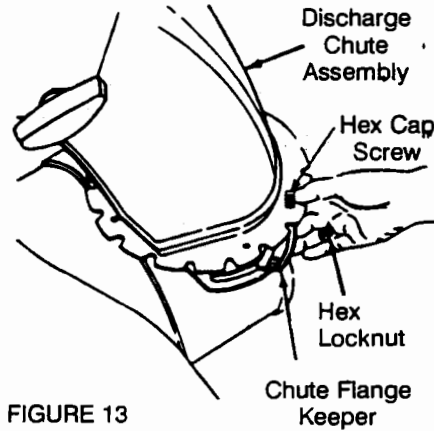

FIGURE 13

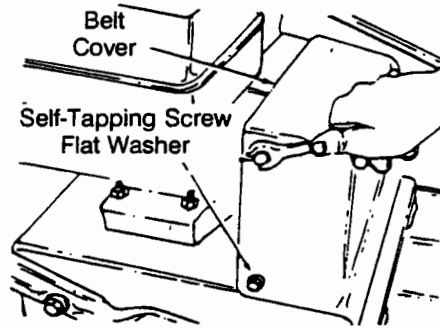

FIGURE 14

- Remove the chute assembly by removing the hex cap screws, chute flange keepers and hex locknuts. See Figure 13.
- Remove the plastic belt cover on the front of the engine by removing three self-tapping screws and flat washers. See Figure 14.

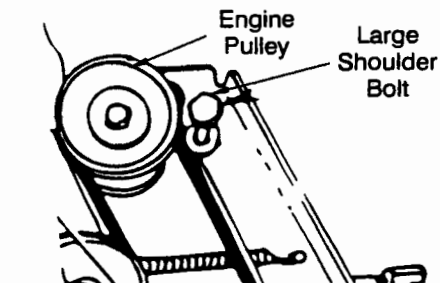

FIGURE 15

- Remove the large shoulder bolt and washer on the left hand side of the engine pulley with an adjustable wrench. See Figure 15.

NOTE: Reference to right hand or left hand side of machine are observed from the operating position.

- Remove the cotter pin and washer from the ferrule in order to disconnect the auger idler rod from the brake bracket assembly as shown in Figure 16.

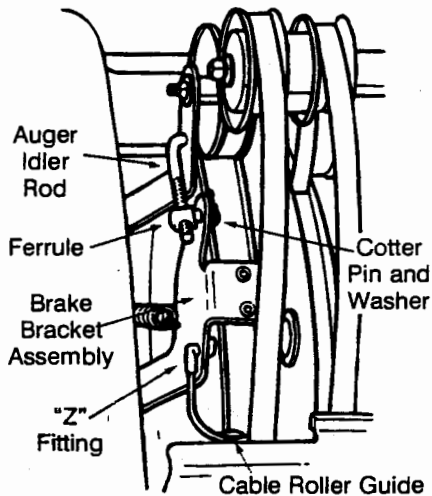

FIGURE 16

- Slip the auger drive belt (the front belt) off the engine pulley. See Figure 18.
- Pull the brake bracket assembly towards the cable guide roller and unhook the auger cable "Z" fitting. See Figure 16.
- Remove the top screws and lockwashers which attach the auger housing assembly to the frame assembly. A 9/16" wrench is required. See Figure 17.
- Separate the auger housing from the frame assembly by tilting the housing forward and pulling up the handles.
- Rest the handle assembly on the ground and tip the remaining half forward to rest on the housing.

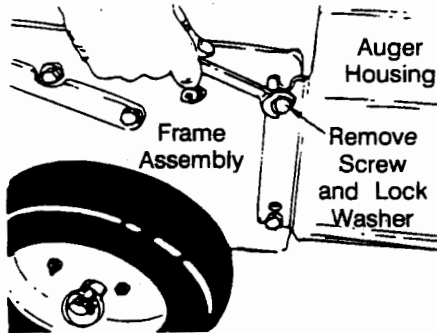

FIGURE 17

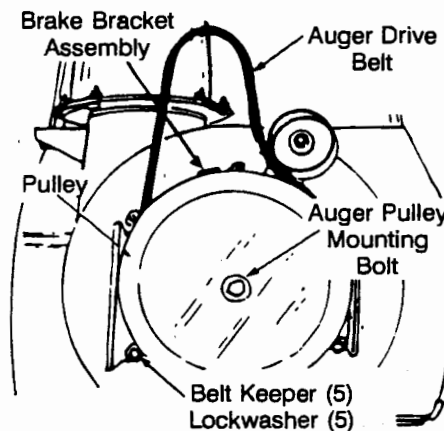

FIGURE 18

To Remove the Auger Drive Belt:

- Using a 9/16" wrench remove the five belt keepers and lockwashers from around the auger pulley. See Figure 18.
- Remove and replace auger drive belt.
- Replace lockwashers and belt keepers.

NOTE: The auger pulley mounting bolt has chemical patch which sets after bolt is assembled. If the bolt is removed for any reason it must be replaced.

NOTE: The brake puck in the brake bracket assembly must always be firmly seated in the pulley groove when the auger clutch lever is in the disengaged position.

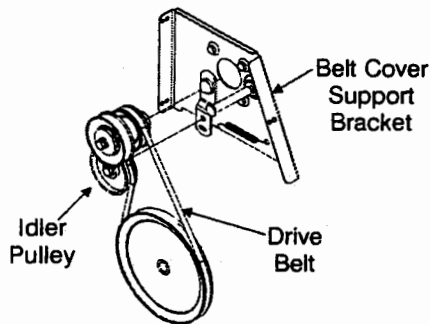

FIGURE 19

NOTE: See Adjustment section for "Auger Belt Adjustment".

To Remove the Drive Belt:

- a. Pull idler pulley away from belt. See Figure 19.
 - b. Remove drive belt from the engine pulley and bottom drive pulley.
 - c. Replace belt and reassemble in reverse order.
- Reassemble the two halves of the unit hooking the lower portion of the auger housing over the stationary shoulder bolts in the frame assembly.
 - Secure the two halves with the two screws and lockwashers.
 - Attach the "Z" fitting of the cable into the brake bracket assembly. See Figure 16.
 - Slip the auger drive belt over engine pulley.
 - Insert ferrule on auger idler rod into bracket assembly and secure with flat washer and cotter pin.
 - Reassemble the large shoulder bolt and lockwasher as shown in Figure 15.
 - Reassemble belt cover, chute assembly and chute crank.

Changing the Friction Wheel

The rubber on the friction wheel is subject to wear and should be checked after 25 hours of operation, and periodically thereafter. Replace the friction wheel rubber if any signs of wear or cracking are found.

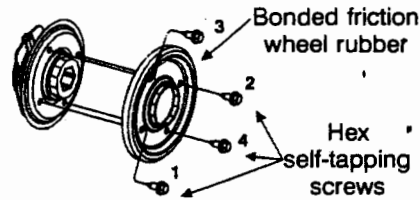

FIGURE 20

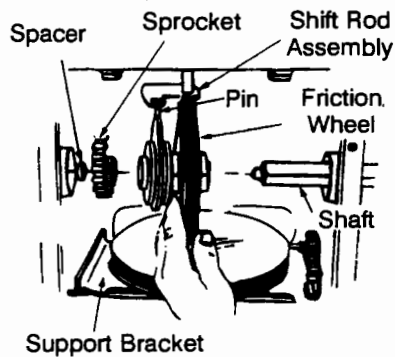

FIGURE 21

- Drain the gasoline from the snowthrower, or place a piece of plastic under the gas cap.
- Tip the snowthrower up and forward, so that it rests on the housing.
- Remove six self-tapping screws from the frame cover underneath the snowthrower and remove cover.
- Remove the wheels from the axle.
- Using a 7/8" wrench hold the hex shaft and remove the hex bolt and cupped washer and bearing from left side of the frame. See Figure 10. Hold the friction wheel assembly, and slide the hex shaft out of the unit toward the right hand side.
- Remove the four screws from the friction wheel assembly and remove the bonded friction wheel.
- Reassemble new bonded friction wheel rubber to the friction wheel assembly, turn each screw approximately 2 turns in order shown in Figure 20 until screws are tight. **It is important for the rubber to be assembled symmetrically.**

- Position the friction wheel assembly up onto the pin of the shift rod assembly and slide the shaft through the friction wheel. See Figure 21.
- Slide the hex shaft into the hex I.D. of the sprocket, the spacer and the left ball bearing and secure with the cupped washer and hex bolt.
- Remove plastic film from gas cap.

NOTE: Make sure the pin from the shift arm assembly is assembled to the new friction wheel assembly.

CAUTION: Check engine and snowthrower frequently for loose nuts, bolts, etc. and keep these items tightened.

STORAGE INSTRUCTIONS



NEVER STORE ENGINE WITH FUEL IN TANK INDOORS OR IN ENCLOSED, POORLY VENTILATED ENCLOSURES, WHERE FUEL FUMES MAY REACH AN OPEN FLAME OR SPARK.

If unit is to be stored over 30 days, prepare for storage as instructed in the separate engine manual packed with your unit.

NOTE: Failure to comply with suggested maintenance and lubrication specifications will void warranty.

TROUBLE SHOOTING

PROBLEM	POSSIBLE CAUSE(S)	CORRECTIVE ACTION
Engine fails to start	<ol style="list-style-type: none"> 1. Fuel tank empty, or stale fuel. 2. Blocked fuel line. 3. Choke not in the FULL position. 4. Faulty spark plug. 5. Safety key not in ignition switch on engine. 6. Spark plug wire disconnected. 7. Primer button not being used properly. 8. Fuel shut-off valve closed. 	<ol style="list-style-type: none"> 1. Fill tank with clean, fresh gasoline. Fuel becomes stale after thirty days. 2. Clean the fuel line. 3. Move switch to the FULL position. 4. Clean, adjust gap or replace. 5. Insert the key fully into the switch. 6. Connect spark plug wire. 7. Refer to the engine manual. 8. Open fuel shut-off valve.
Engine runs erratic	<ol style="list-style-type: none"> 1. Unit running on CHOKE. 2. Blocked fuel line or stale fuel. 3. Water or dirt in the fuel system. 	<ol style="list-style-type: none"> 1. Move the choke lever to OFF position. 2. Clean the fuel line; fill the tank with clean, fresh gasoline. 3. Drain the fuel tank and carburetor. Refill with fresh fuel.
Loss of power	<ol style="list-style-type: none"> 1. Spark plug wire loose. 2. Gas cap vent hole plugged. 	<ol style="list-style-type: none"> 1. Connect and tighten spark plug wire. 2. Remove ice and snow from gas cap. Be certain vent hole is clear.
Excessive vibration	<ol style="list-style-type: none"> 1. Loose parts or damaged auger. 	<ol style="list-style-type: none"> 1. Stop the engine immediately and disconnect the spark plug wire. Tighten all bolts and nuts. If vibration continues, have the unit serviced by an authorized service dealer.
Unit fails to drive properly	<ol style="list-style-type: none"> 1. Drive control cable in need of adjustment. 2. Drive belt loose or damaged. 	<ol style="list-style-type: none"> 1. Adjust drive control cable. Refer to Adjustment Section of this manual. 2. Replace drive belt. Refer to Belt Removal and Replacement.
Unit fails to discharge snow	<ol style="list-style-type: none"> 1. Discharge chute clogged. 2. Shear bolt sheared. 3. Foreign object lodged in auger. 4. Auger control cable in need of adjustment. 5. Auger belt loose or damaged. 	<ol style="list-style-type: none"> 1. Stop engine and disconnect spark plug wire. Clean discharge chute and inside of auger housing with tool provided. 2. Replace shear bolt. 3. Stop engine immediately and disconnect spark plug wire. Remove object from auger. 4. Adjust auger control cable. Refer to Adjustment section of this manual. 5. Refer to Belt Removal and Replacement.
Heated grips are not creating heat	<ol style="list-style-type: none"> 1. Unit is not running. 2. Loosen electrical connections. 3. Blown Fuse. 4. Faulty grip. If one heated grip fails, both grips will not function. 	<ol style="list-style-type: none"> 1. Start the unit 2. Under the handle panel, check connections from the handles to the wiring harness. 3. Replace 5A fuse under the handle panel near crank switch connector. 4. Have the grips checked at an authorized service dealer.

THREE (3) YEAR LIMITED WARRANTY

For three (3) years from the date of original purchase of our products, we will either repair or replace, at its option, free of charge, F.O.B. Factory or authorized service firm, any part found to be DEFECTIVE IN MATERIAL and WORKMANSHIP for the original purchaser. All transportation charges on parts submitted for replacement under this warranty must be paid by the purchaser unless return is requested by the manufacturer.

This warranty DOES NOT apply to any part which has become inoperative through misuse, excessive use, accident, neglect, improper maintenance or alterations by unauthorized persons.

The limited warranty does not extend to the replacement of parts which are not defective, but where regular usage has exhausted the life of the part.

ENGINES, ELECTRIC START KITS, PEERLESS TRANSMISSIONS AND PEERLESS TRANSAXLES ARE WARRANTED BY THEIR RESPECTIVE MANUFACTURER. ALL CLAIMS AGAINST THESE COMPONENTS MUST BE HANDLED THROUGH THE RESPECTIVE MANUFACTURER'S SERVICE DEALERS.

Belts, light bulbs, clutch parts (friction wheels), grass bags, tires, seats, rider deck wheels and cutting blades are covered by a 60 day limited warranty.

Batteries are covered by a 90 day limited warranty.

Fuses, shear bolts and blade adapters are considered consumable items and as such are not warranted.

NOTE: Regular maintenance replacement parts and related inspections and adjustments are excluded from coverage when made as part of normal maintenance service.

TRACTOR ATTACHMENT WARRANTY

Mower decks included with your product, or sold separately, as an attachment for your garden tractors will be warranted according to the above terms of the manufacturer three (3) year limited consumer warranty.

ALL OTHER ATTACHMENTS will be sold under the same condition as above except the warranty will be ONE YEAR FROM DATE OF ORIGINAL PURCHASE.

PERSONAL USE

THE FOREGOING PARAGRAPHS CONSTITUTE THE MANUFACTURER'S ENTIRE WARRANTY WITH RESPECT TO ANY PRODUCT PURCHASED AND USED FOR PERSONAL FAMILY, HOUSEHOLD/RESIDENTIAL PURPOSES, AS DISTINGUISHED FROM COMMERCIAL USAGE.

COMMERCIAL USE

ALL APPLICATIONS OTHER THAN PERSONAL USE AS OUTLINED ABOVE, ARE CONSIDERED COMMERCIAL USAGE.

New products purchased for commercial usage are warranted in the same manner and to the same extent EXCEPT the term of warranty will be 60 DAYS from date of purchase, 90 days if your unit is equipped with an OHV engine. "

WARRANTY SERVICE CAN ONLY BE PERFORMED BY AN AUTHORIZED SERVICE DEALER. ANY NON-ORIGINAL EQUIPMENT REPLACEMENT PART USED ON OR IN A PRODUCT UNDER WARRANTY WILL BE EXCLUDED FROM THAT WARRANTY COVERAGE, AS WILL BE ANY RELATED DAMAGED COMPONENTS RESULTING FROM THE INSTALLATION OF A REPLACEMENT PART FROM ANOTHER SOURCE OTHER THAN THE MANUFACTURER.